

T&T

R&D, Project Management and Consulting

Catalogue

Version 3 10-2018

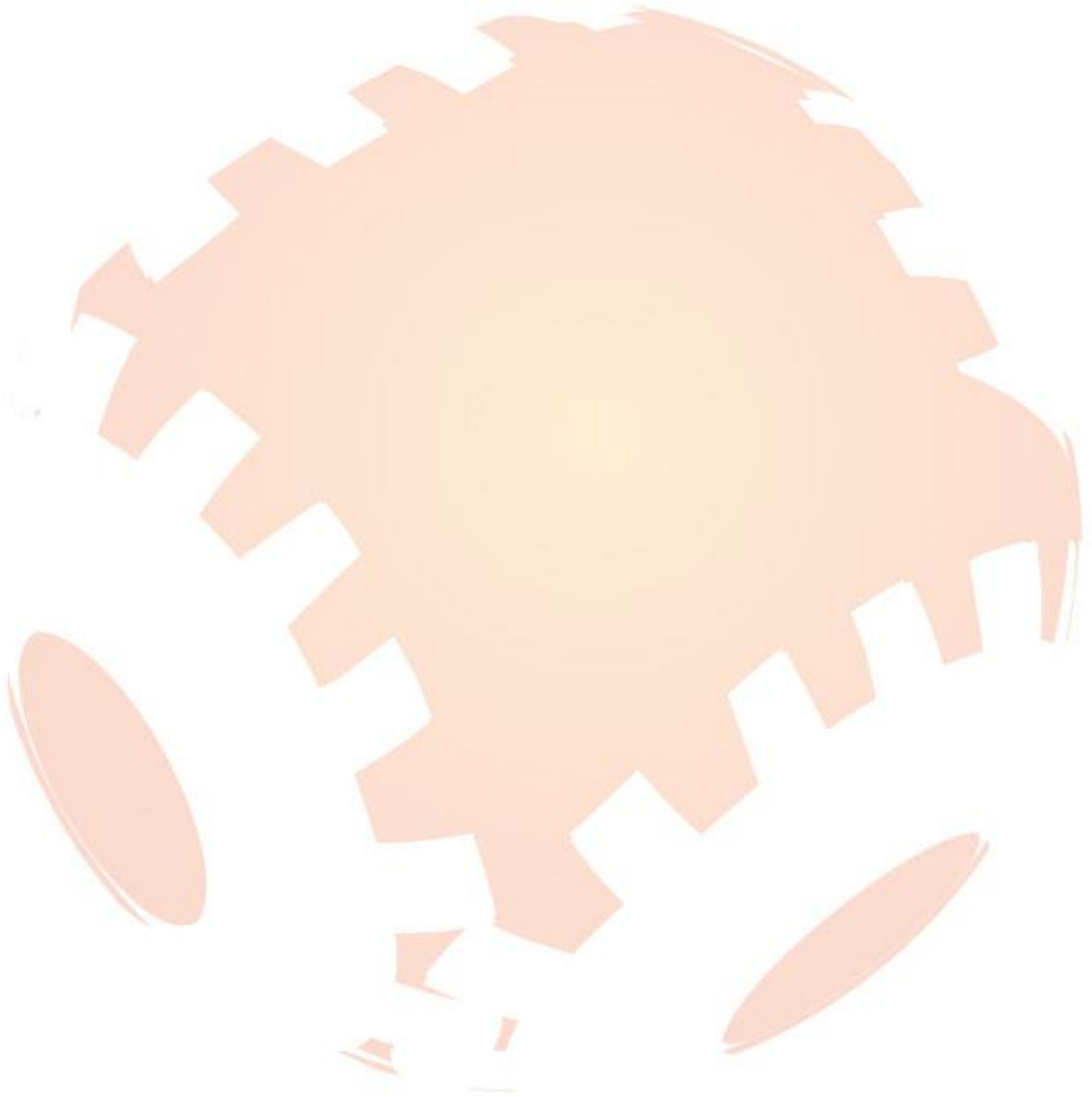

Note: Other catalogues for variables are available on request.

© T&T, Turnov s.r.o.

POSITIONER P&B

70 mm max. finish

TYPE – DG 4 ¼“, DG 5“, TG 4 ¼“

for Emhart IS machine

No.: T90003252



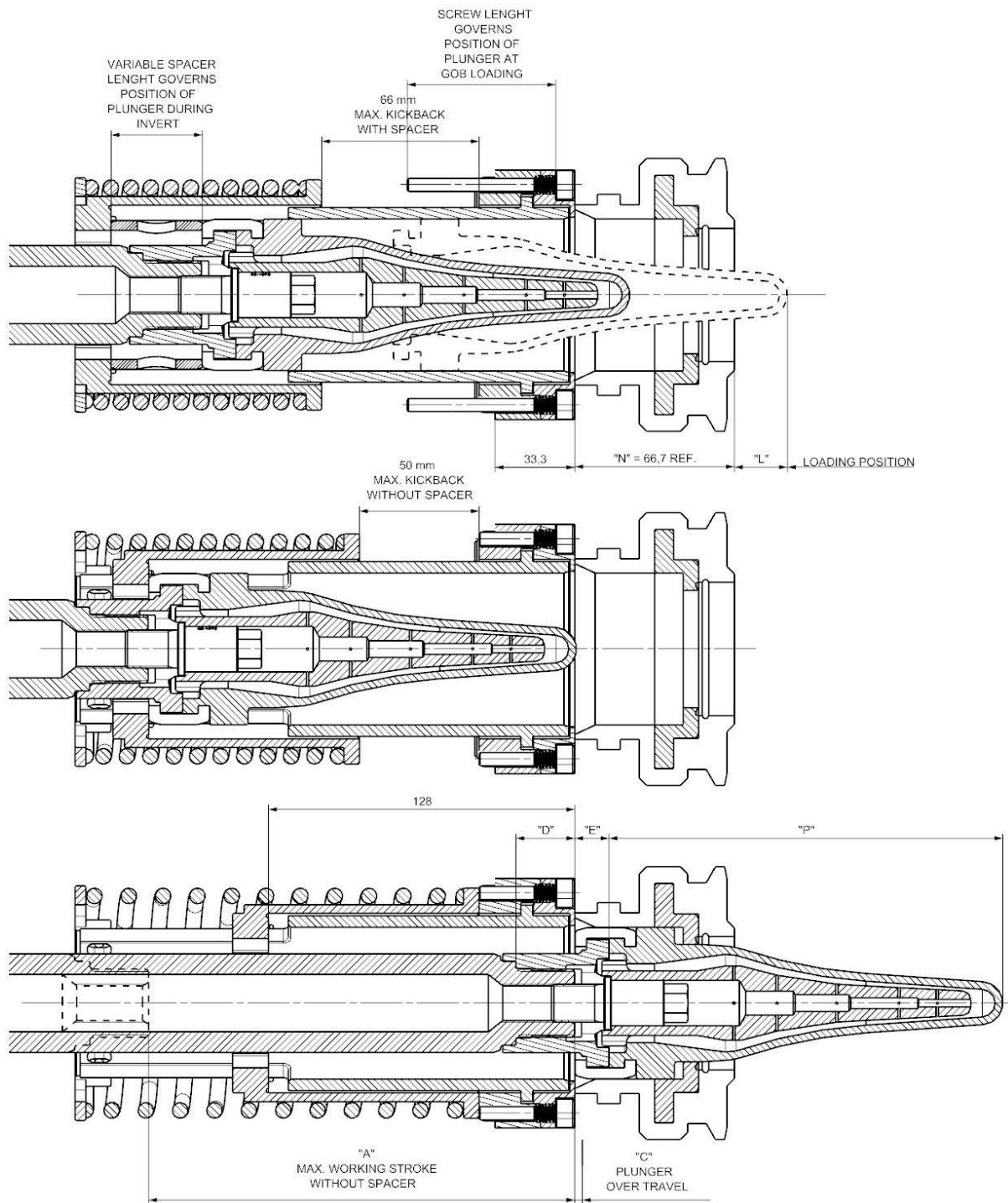

$$\text{LOADING SPACER LENGTH} = 128 + N + L - (P + 12,7)$$

PLUNGER MECH.	A	C	D	E
WITH SENSOR	173	8	29,4	9,5
WITHOUT SENSOR	178	3,2	24,6	14,3

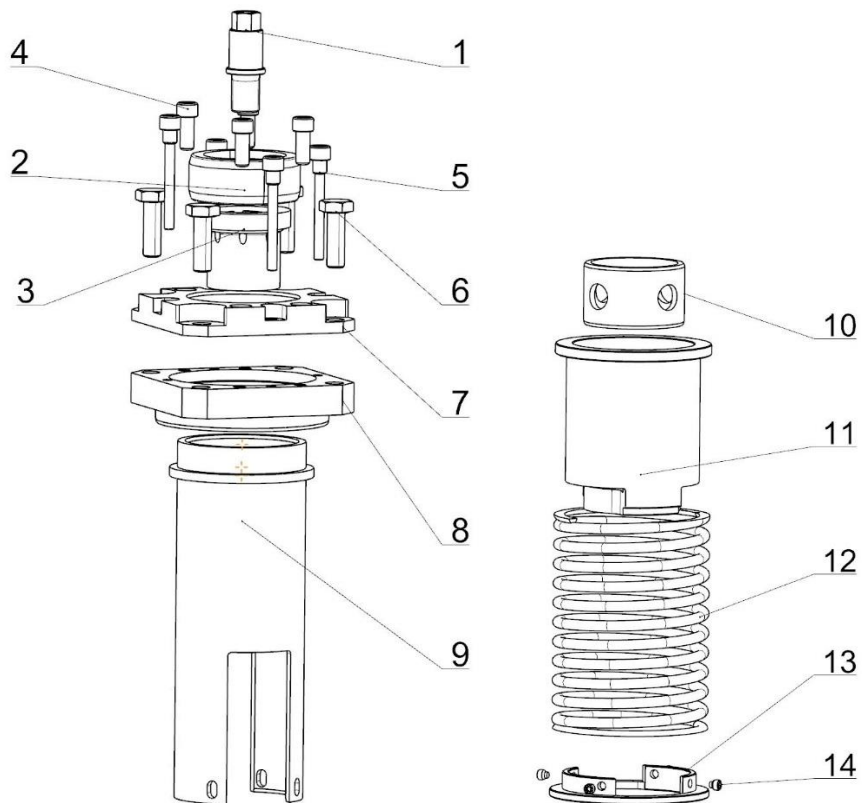

ITEM NO.	PART NUMBER	DESCRIPTION	QTY.
1	T90003261	LOCK SCREW	1
2	T90003260	CLAMP RING	1
3	T90003259	ADAPTER	1
4	T50000999	SCREW 5/16"-18UNC-3/4"	4
5	T90003265	LOAD SCREW	4
6	T50001346	SCREW 3/8"-16 UNC-1 1/4"	4
7	T90003253	CUP	1
8	T90003254	FLANGE	1
9	T90003255	GUIDE TUBE	1
10	T90003264	SPACER SET	1
11	T90003256	SLEEVE	1
12	T90003263	SPRING	1
13	T90003257	SPRING LOCATOR	1
14	T50001000	SCREW 1/4"-20 UNC-1/4"	4

Comment:

No. T90003264 SPACER SET contain 7pcs with different length (1/4", 1/2", 3/4", 1", 1 1/2", 2" and 2 1/2")

SECTION A-A

